



Guidance Document Infectious Substances

Note:

1. *The following Guidance Document was developed by the ICAO DGP. The original ICAO document reflects references to the ICAO Technical Instructions these have been amended to reflect the references applicable to the 48th Edition (2007) of the IATA Dangerous Goods Regulations (DGR).*

Introduction

Provisions applicable to the classification of Infectious Substances were extensively revised and then published in the 13th and 14th revised editions of the UN Recommendation on the Transport of Dangerous Goods (Model Regulations). The revised provisions were developed in coordination with experts from the World Health Organization (WHO) and other technical experts in the field of transport, packaging and health.

The purpose of this document is to provide guidance for complying with provisions applicable to the transport by air of infectious substances as set out in the DGR. Specifically the document provides guidance on:

- Definitions;
- Classification;
- Exceptions;
- Packaging Provisions for Infectious Substances, affecting humans or animals, UN 2814 or UN 2900;
- Packaging Provisions for Biological Substances, Category B, UN 3373;
- Packaging for Exempt Patient Specimens;
- Prohibitions;
- Passenger Provisions;
- Training and Emergency Response.

Definitions

Infectious substances are substances which are known to contain, or are reasonably expected to contain, pathogens. Pathogens are defined as micro-organisms (including bacteria, viruses, rickettsiae, parasites, fungi) and other agents such as prions, which can cause disease in humans or animals.

Cultures are the result of a process by which pathogens are intentionally propagated. This definition does not include human or animal patient specimens.

Patient specimens are those collected directly from humans or animals, including, but not limited to, excreta, secreta, blood and its components, tissue and tissue fluid swabs, and body parts being transported for purposes such as research, diagnosis, investigational activities, disease treatment and prevention.

Medical or clinical wastes are wastes derived from the medical treatment of animals or humans or from bio-research.

Classification

For transport purposes the classification of infectious substances according to risk groups was removed from the DGR in the 46th edition (2005).

Infectious substances are now classified either as Category A or Category B.

There is no direct relationship between Risk Groups and categories A and B.

Category A Infectious Substances are infectious substances in a form that, when exposure to it occurs, is capable of causing permanent disability, life-threatening or fatal disease in otherwise healthy humans or animals. They are assigned the following UN numbers and proper shipping names:

- UN 2814 – **Infectious Substance, affecting humans**; or
- UN 2900 – **Infectious Substance, affecting animals** *only*.

Assignment to UN 2814 or UN 2900 is to be based on the known medical history and symptoms of the source human or animal, endemic local conditions, or professional judgement concerning individual circumstances of the source human or animal. If there is any doubt as to whether or not a pathogen falls within this category it must be transported as a Category A Infectious Substance.

Clinical wastes containing Category A infectious substances must be assigned to UN 2814 or UN 2900, as appropriate.

To assist in the assignment of an infectious substance into Category A see the Indicative List provided in Table 3.6.D in the DGR. That list, however is not exhaustive. Infectious substances, including new or emerging pathogens, which do not appear in the table but which meet the same criteria must be assigned to Category A.

Category B Infectious Substances are Infectious Substances that do not meet the criteria for inclusion in Category A. They are assigned the following UN number and proper shipping name:

- UN 3373 – **Biological Substance, Category B**

Clinical wastes containing Category B infectious substances must be assigned to UN 3291.

Further assistance on the classification of infectious substances can be obtained from the national health or veterinary authority. (See Annex 1 for Classification Scenarios and Annex 2 for a Classification Flowchart.)

Exceptions

- Substances, which do not contain infectious substances, or substances, which are unlikely to cause disease in humans or animals, are not subject to the IATA DGR unless they meet the criteria for inclusion in another class;
- Substances containing micro-organisms, which are non-pathogenic to humans or animals are not subject to the DGR unless they meet the criteria for inclusion in another class;
- Substances in a form that any present pathogens have been neutralized or inactivated such that they no longer pose a health risk are not subject to the DGR unless they meet the criteria for inclusion in another class;

- Environmental samples (including food and water samples), which are not considered to pose a significant risk of infection, are not subject to the DGR unless they meet the criteria for inclusion in another class;
- Dried blood spots, collected by applying a drop of blood onto absorbent material, or faecal occult blood screening tests and blood or blood components which have been collected for the purposes of transfusion or for the preparation of blood products to be used for transfusion or transplantation and any tissues or organs intended for use in transplantation are not subject to the DGR;
- Patient specimens for which there is minimal likelihood that pathogens are present are not subject to the DGR if the specimen is transported in Packaging for Exempt Patient Specimens (**see below for the Packaging requirements for Exempt Patient Specimens**).

Note:

In determining whether a patient specimen has a minimal likelihood that pathogens are present, an element of professional judgement is required. That judgement should be based on the known medical history, symptoms and individual circumstances of the source, human or animal, and endemic local conditions. Examples of specimens which may be transported as a patient specimen for which there is a minimal likelihood that pathogens are present include blood or urine tests to monitor cholesterol levels, blood glucose levels, hormone levels, or prostate specific antigens (PSA); tests required to monitor organ function such as heart, liver or kidney function for humans or animals with non-infectious diseases, or therapeutic drug monitoring; tests conducted for insurance or employment purposes and are intended to determine the presence of drugs or alcohol; pregnancy tests; biopsies to detect cancer; and antibody detection in humans or animals.

Packaging for Exempt Patient Specimens

Patient specimens (human or animal) that have a minimal likelihood of containing pathogens must be packaged appropriately to further minimize the risk of exposure. While these specimens have a minimal likelihood of containing infectious pathogens in a form that would cause infection, appropriate packaging further minimizes the risk of exposure. Exempt human or animal specimens must be packaged and marked according to the following:

- (i) a leak-proof primary receptacle(s);
- (ii) a leak-proof secondary packaging; and
- (iii) an outer packaging of adequate strength for its capacity, mass and intended use, and with at least one surface having minimum dimensions of 100 mm x 100 mm;

For liquids, absorbent material in sufficient quantity to absorb the entire contents must be placed between the primary receptacle(s) and the secondary packaging so that, during transport, any release or leak of a liquid substance will not reach the outer packaging and will not compromise the integrity of the cushioning material.

When multiple fragile primary receptacles are placed in a single secondary packaging, they must be either individually wrapped or separated to prevent contact between them. If such a packaging is used it must be marked "Exempt human specimen" or "Exempt animal specimen", as appropriate.

(See Annex 5 for a graphic depiction of an Exempt Patient Specimen Packaging)

If other dangerous goods are present with patient specimens the relevant provisions of the DGR apply to those goods.

When dangerous goods intended for air transport are carried by surface transport to or from an airport, any other applicable national or modal transport requirements should be met in addition to those that are applicable for the goods when carried by air.

Packaging Provisions for Infectious Substances, humans or animals, UN 2814 or UN 2900

Packing Instruction 602 in the DGR specifies the type of packaging required for all Category A infectious substances. All other applicable provisions of the DGR apply (See *Annex 3 for a graphic depiction of a package containing category A infectious substances*).

Packaging Provisions for Biological Substances, Category B, Clinical Specimens, Diagnostic Specimens, UN 3373

Packing Instruction 650 in the DGR provides all the information necessary to prepare and transport Category B infectious substances (*See Annex 4 for a graphic depiction of a package containing category B infectious substances*).

Prohibitions

A live animal that has been intentionally infected and is known or suspected to contain an infectious substance must not be transported by air unless the infectious substance contained cannot be consigned by any other means. Infected animals may only be transported under terms and conditions approved by the appropriate national authority.

Passenger Provisions

Category A or B Infectious Substances are not permitted for transport in carry-on or checked baggage and must not be carried on a person. Packages containing Exempt human or animal specimens may be carried in checked or carry-on baggage provided that they meet the applicable packaging requirements.

Training and Emergency Response

Effective employee training and appropriate emergency response procedures are required to significantly minimize the risk of exposure and subsequent transmission of infection or disease.

Mitigation procedure:

DO NOT CLEAN-UP OR DISPOSE OF INFECTIOUS SUBSTANCES, EXCEPT UNDER SUPERVISION OF A SPECIALIST.

- Isolate spill or leak area immediately.
- Keep unauthorized personnel away.
- Obtain identity of substance involved if possible and report the spill to the appropriate authorities.
- Do not touch or walk through spilled material.
- Do not touch damaged containers or spilled material unless wearing appropriate protective clothing.
- Be particularly careful to avoid contact with broken glass or sharp objects that may cause cuts or abrasions that could significantly increase the risk of exposure.
- Damaged packages containing solid CO₂ (dry ice) used as a refrigerant may produce water or frost from condensation of air. Do not touch this liquid as it could be contaminated by the contents of the parcel.
- Liquid nitrogen may be present and can cause severe burns.
- Absorb spilled materials with earth, sand or other non-combustible material while avoiding direct contact.
- Cover damaged package or spilled material with damp towel or rag and keep wet with liquid bleach or other disinfectant. Liquid bleach will generally effectively inactivate the released substance.

First Aid:

- Move exposed person(s) to a safe isolated area.

CAUTION: Exposed person(s) may be a source of contamination. Persons administering first aid should take precautions to avoid personal exposure or secondary contamination of others.

- Call emergency medical services.
- If clothing and/or shoes are significantly contaminated, remove and isolate them. However, do not allow this to delay other first aid interventions.
- In case of contact of the substance to skin, eyes, nose or mouth, immediately flush the exposed area with copious amounts of running water. Continue this until emergency medical services arrives. Follow their advice for further decontamination.
- Most effects of exposure (inhalation, ingestion or skin contact) to substance are likely to be delayed.
- Ensure that medical personnel are aware of the substances involved so they can take precautions to protect themselves.

For further assistance, contact the appropriate public health authority

ANNEX 1 - Classification Scenarios

1. A blood sample known or reasonably suspected to contain EBOLA VIRUS.
Appropriate classification: Infectious substances, affecting humans UN 2814.
2. A culture of FOOT AND MOUTH DISEASE.
Appropriate classification: Infectious substances, affecting animals, UN 2900.
3. A blood sample taken from a patient known or suspected to have a category B pathogen, such as HEPATITIS B or HIV.
Appropriate classification: Biological substance, category B, UN 3373.
4. Culture of BOVINE TUBERCULOSIS.
Appropriate classification: Biological substance, category B, UN 3373.
5. Laboratory stock culture of a pathogen in category B, e.g. INFLUENZA VIRUS.
Appropriate classification: Biological substance, category B, UN 3373.
6. Specimen containing a category A or B infectious substance, treated so as to inactivate or neutralise the pathogens such that they no longer pose a health risk.
Appropriate classification: Not subject to the transport requirements for dangerous goods, unless meeting the criteria for another class or division.
7. Patient specimens other than those known or reasonably suspected to contain a category A infectious substance e.g. those sent for testing for Cholesterol (blood), diabetes (urine), bowel cancer (faecal).
Appropriate classification: this will depend on professional judgement, i.e.:
 - (i) If a professional judgement is made that there is only a minimal likelihood that pathogens are present, the specimen is not subject to the provisions of the DGR, provided they are packed in accordance with the provisions detailed under "Packaging for Exempt Patient Specimens" in this Guidance Document;
 - (ii) If no professional judgement is made, the specimen must be classified as UN3373.

ANNEX 2 – Classification Flowchart

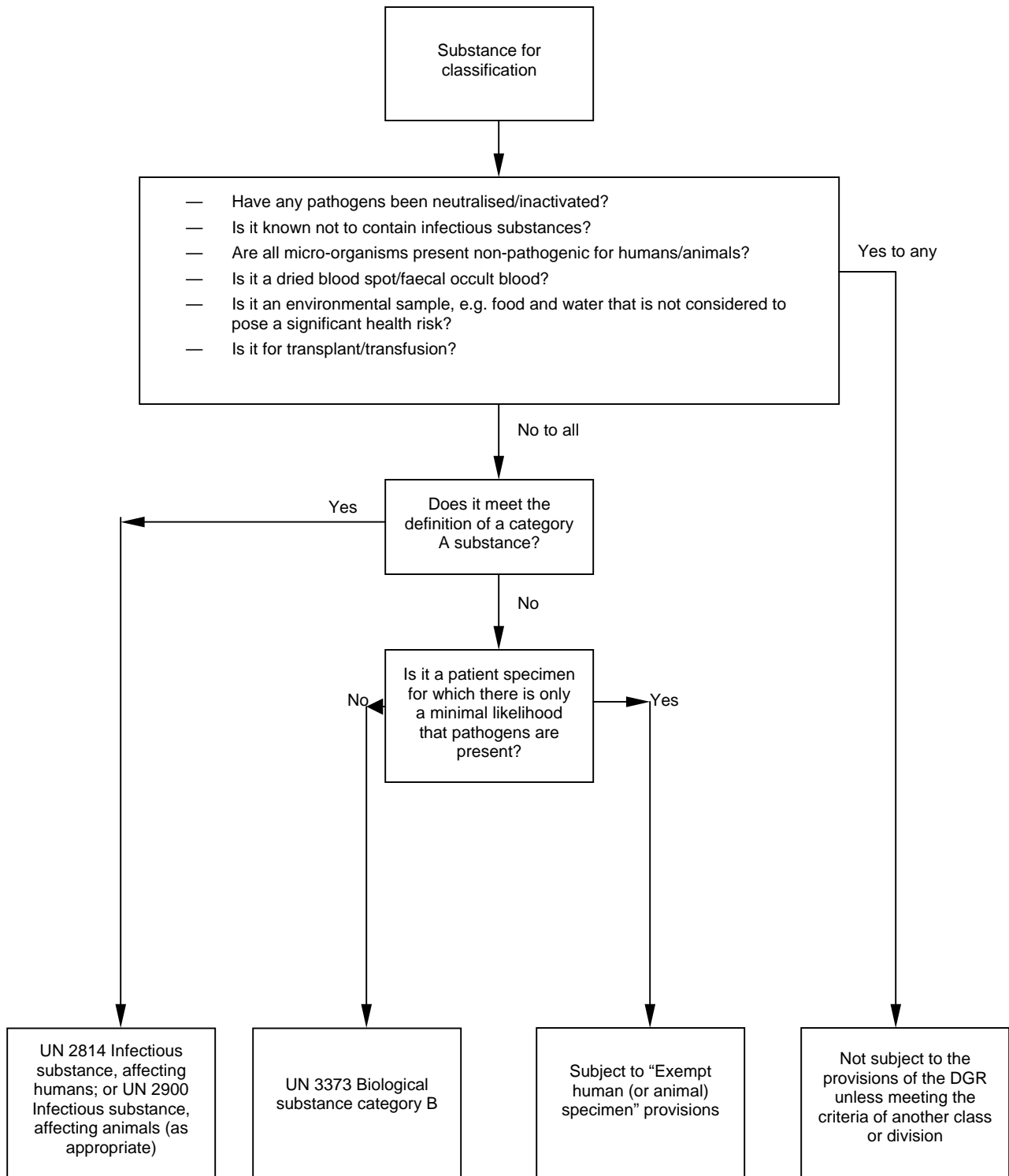

ANNEX 3

Example of Packing and Marking for Category A Infectious Substances

(See Packing Instruction 602 for additional requirements)

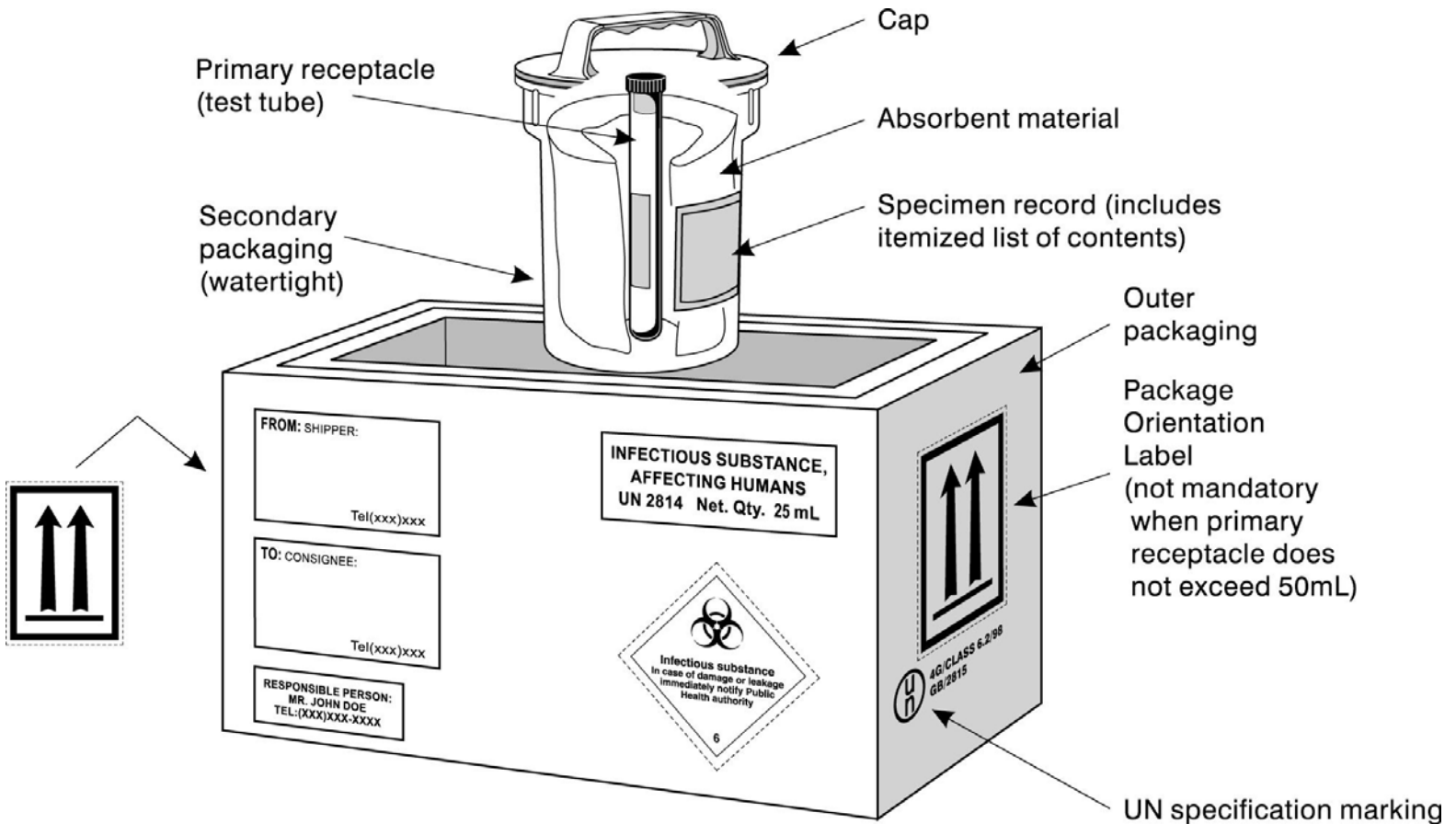

Notes:

1. The smallest external dimension of the outer packaging must not be less than 100 mm;
2. The primary receptacle or the secondary packaging must be capable of withstanding, without leakage, an internal pressure producing a pressure differential of not less than 95 kPa.

ANNEX 4

Example of Packing and Marking for Category B Infectious Substances

(See Packing Instruction 650 for additional requirements, e.g. drop test)

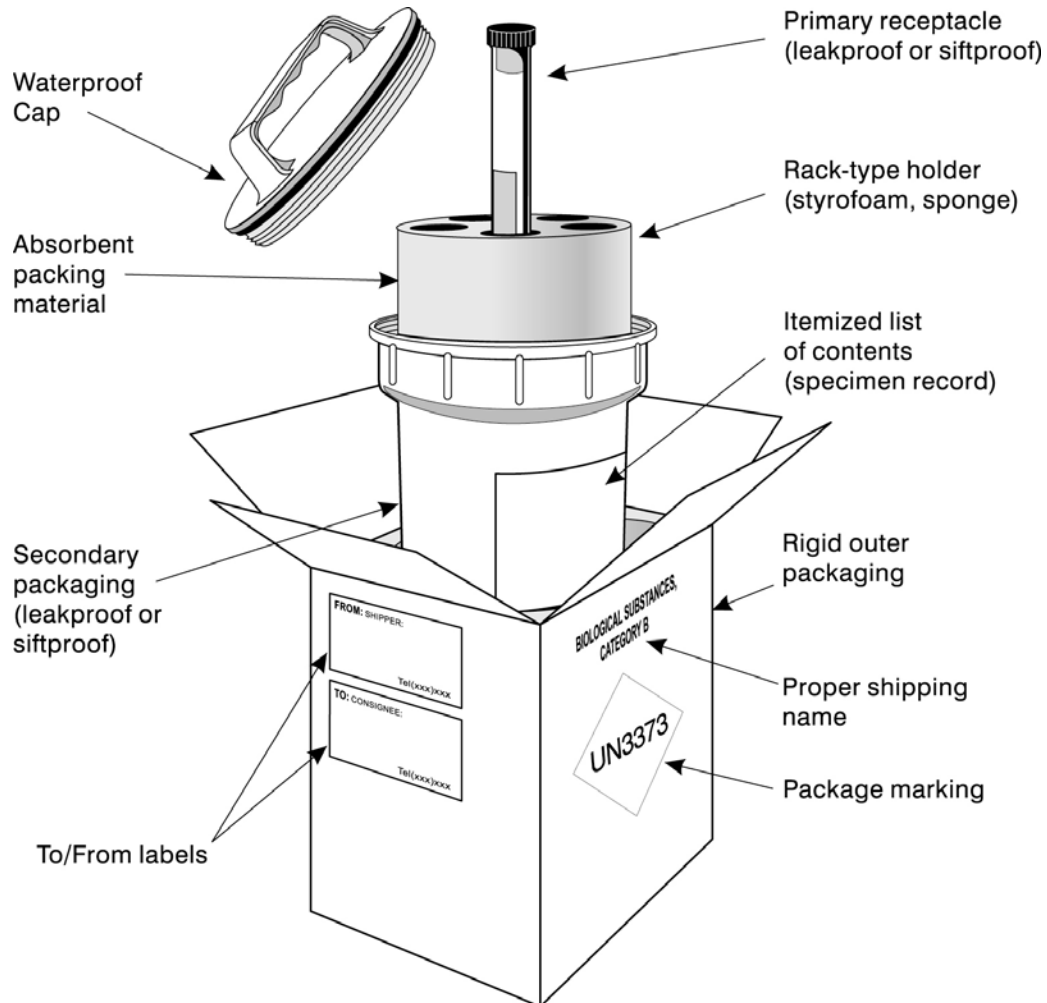

Notes:

1. At least one surface of the outer packaging must have a minimum dimension of 100 mm x 100 mm;
2. The primary receptacle or the secondary packaging must be capable of withstanding, without leakage, an internal pressure producing a pressure differential of not less than 95 kPa.

ANNEX 5

Example of Packing and Marking for Exempt Specimens

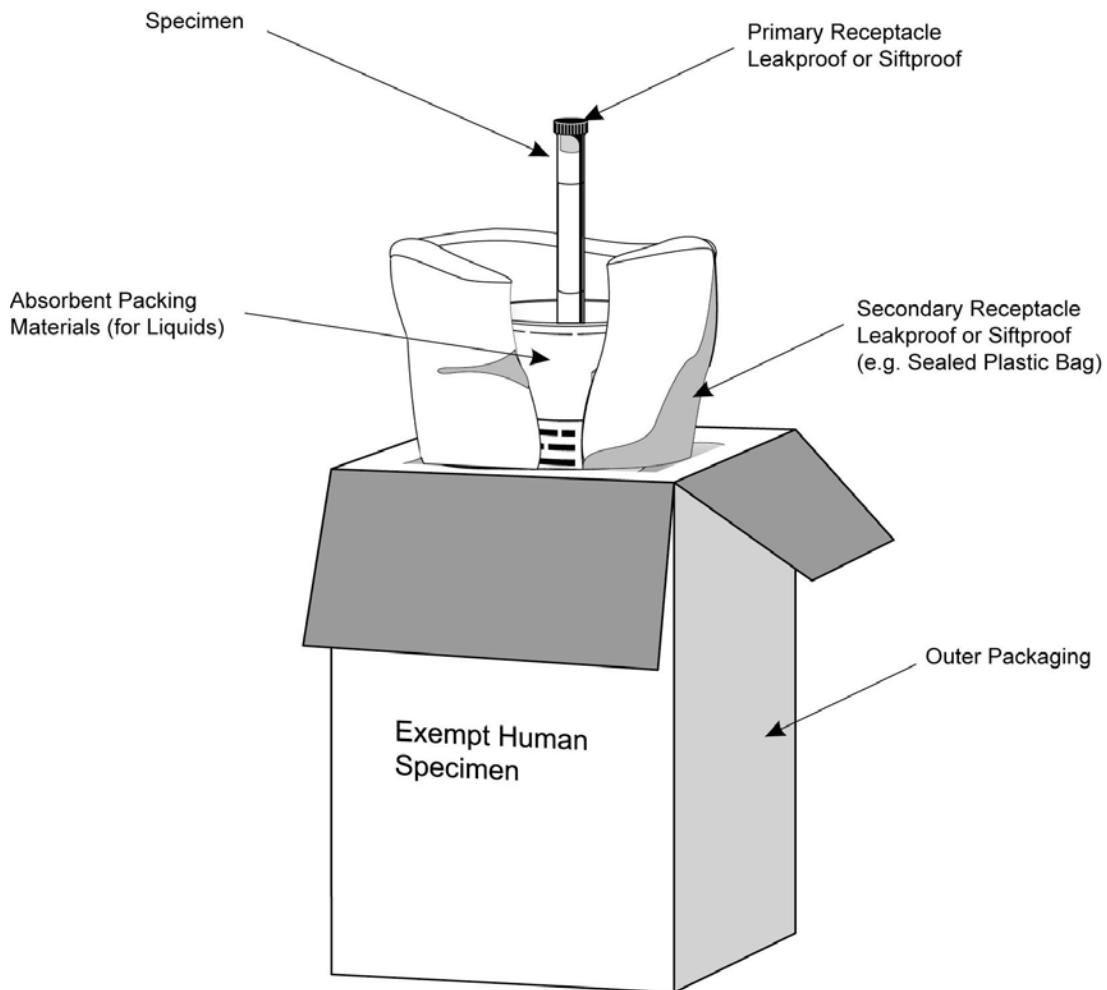

Notes:

1. At least one surface of the outer packaging must have a minimum dimension of 100 mm x 100 mm;
2. The outer packaging must be of adequate strength for its capacity, mass and intended use.